



THE LOFT BOYS



*The Leading Loft Boarding &
Ladder Experts in the UK*

2016 BROCHURE

LOFT LADDERS & ACCESS

INSULATION

ROOF WINDOWS

VENTILATION SYSTEMS

LIGHTING & POWER

FLOORING

INSTALLATION SERVICES

0800 6128 933

www.theloftboys.co.uk

ABOUT US

The idea behind The Loft Boys was born after Dean Taylor, founder and CEO, learnt that there was very little choice for people like you looking to utilise their loft space without the huge expense of employing a full loft conversion company.

Dean initially operated this service as a sole trader operating from home, but it wasn't long before the demand became too much to handle by himself. Dean needed to recruit, and recruit fast, if he was to keep up with demand. The only hurdle he faced was finding staff with full the range of skills and knowledge needed to meet his strict standards. The Loft Boys were born!



“After some years of working for a family business who specialised in full loft conversions I was amazed at the amount of basic loft boarding work being turned away due to the jobs being deemed as ‘too small’. This led me to explore what options people had when looking for smaller levels of loft work. I found out that there were very few companies or sole traders offering this service—and often they only served a small, localised, area. I created The Loft Boys to address this.”

Dean Taylor, Founder & CEO of The Loft Boys

We operate in a large coverage area in the South East of England

For a comprehensive list places we cover please visit: www.theloftboys.co.uk/loft-locations

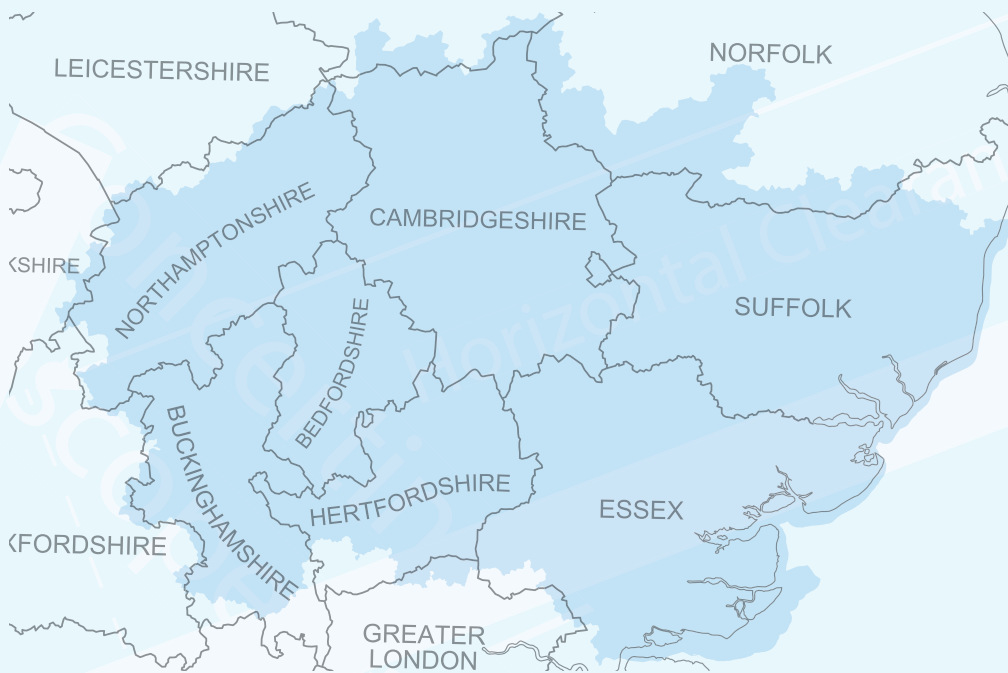

Get in touch

Telephone: **0800 6128 933**
 Telephone: **01992 679077**
 Email: **lofts@theloftboys.co.uk**
 Web: **www.theloftboys.co.uk**

The Loft Boys Ltd.
 Unit 10 Impressa Park
 Pindar Road, Hoddesdon
 Hertfordshire, EN11 0DL

Company Registered in England (No. 7443609), VAT Reg No (102 2838 52) and registered office (The Loft Boys Ltd, Brentmead House, Britannia Road, London, N12 9RU). All images in this publication are for illustration purposes only. E&OE – 05/03/2015.

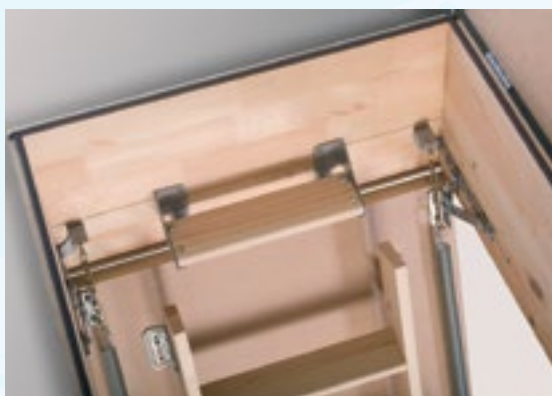

LOFT LADDERS & ACCESS 4-16

- Independent Loft Ladders 5-6
- Integrated Loft Ladders 7-8
- Integrated Wall/Vertical Access Ladders 9
- Hatches 10

INSULATION 11

ROOF WINDOWS 12-15

- Velux Roof Windows 12-14
- Roof Window Accessories 15

VENTILATION SYSTEMS 16

LIGHTING & POWER 17

FLOORING 18-19

INSTALLATION SERVICES 20

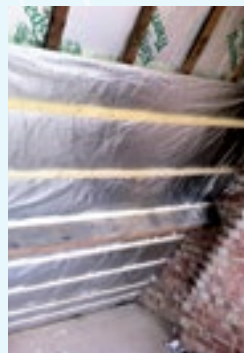

REMEMBER, WE GIVE YOU A 5 YEAR GUARANTEE ON ALL OUR PRODUCTS AND INSTALLATIONS, SO SHOULD SOMETHING GO WRONG, WE'LL PUT IT RIGHT!

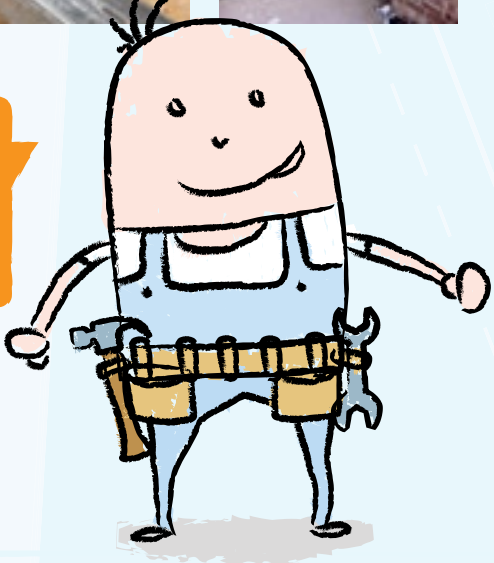

Installer partners



LOFTZONE
STOREFLOOR
AUTHORISED INSTALLER

Powered by

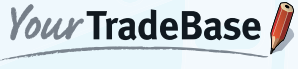

LOFT LADDERS & ACCESS

Everything you need to access your loft space

We've all done it! Standing on a rickety set of steps or old dining room chair, and pulling yourself up through that little hole in the ceiling just to retrieve the suitcases for your holiday. There's no need to put you neck on the line any more...

There's a great range of purpose designed ladders available, that not only make getting into your loft safer, but are extremely easy to use. The Loft Boys love safety, which led us to put this comprehensive range of ladders together which will cater for any requirement in any property. You'll even see that we've created a guide to make the decision process easier for you.



Independent Loft Ladders

Pages 5 - 6



Integrated Loft Ladders

Pages 7 - 8



Wall/Vertical Access Ladders

Page 9



Loft Ladder Accessories

Page 8

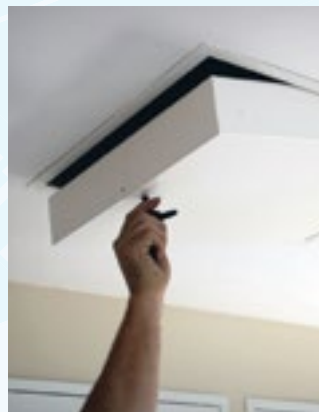

Hatches

Page 10

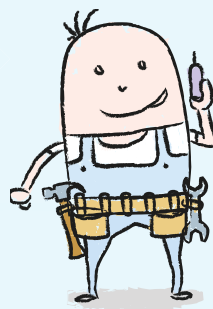

IF YOU CAN'T DECIDE WHICH LADDER IS BEST FOR YOU TALK TO OUR FRIENDLY EXPERTS WHO WILL HELP YOU FIND THE PERFECT SOLUTION.

CALL US ON 0800 6128 933

Stand-alone loft ladders with hatches not included

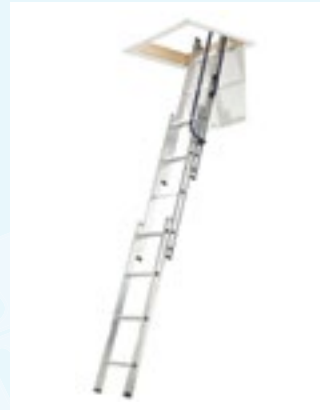

Basic 2 Section Loft Ladders

These 2 section sliding metal ladders are a low-cost solution, ideal for occasional domestic use. Operates independently from the hatch.

- Up to 150kg max load
- Handrail (B2W only)
- Lightweight aluminium
- Max. floor to floor height of 2.6m
- For minimum hatch size of 406mm x 457mm



Non-slip treads



Rubber feet

Basic 3 Section Loft Ladders

These 3 section sliding metal ladders are a popular solution, designed for occasional domestic use. Operates independently from the hatch.

- Up to 150kg max load
- Handrail as standard
- Lightweight aluminium
- Max. floor to floor height of 3m
- For minimum hatch size of 432mm x 508mm



Handrail



Non-slip treads



Rubber feet

Basic Spring Assisted 3 Section Loft Ladder

This 3 section sliding metal ladder features a spring assisted system which helps makes lowering or stowing the ladder very easy.

- Up to 150kg max load
- In-loft handrail for added safety
- Lightweight aluminium
- Max. floor to floor height of 3m
- For minimum hatch size of 380mm x 400mm



Handrail



Non-slip treads



Rubber feet



Spring assisted

100kg max load

Code: B2Y

£137.00

Inc. VAT & Installation

100kg max load

Code: B3Y

£177.00

Inc. VAT & Installation

Code: BS3W

£247.00

Inc. VAT & Installation

150kg max load

Code: B2W

£157.00

Inc. VAT & Installation

150kg max load

Code: B3W

£197.00

Inc. VAT & Installation

Choosing the right ladder

We supply a wide range of ladders, from those intended for infrequent domestic use to those built for industrial premises.

The most important factor in choosing a ladder is to figure out how often you're likely to use it. Our cheapest ladders are suitable for people who only go into their lofts occasionally but if you use your loft frequently then you'll need a robust ladder that will stand up to wear and tear.

How easy it is to lower or stow your ladder is also another factor in choosing the right one for you. We supply ladders that you manually stow with a pole as well as those with a powerful spring action that makes it very easy to put away after using.

Independent loft ladders explained

These ladders are supplied without hatches & trapdoors but the prices shown include full installation by our highly experienced team. These ladders require purchase of a separate hatch (see hatches on page X).

What does floor to floor mean?

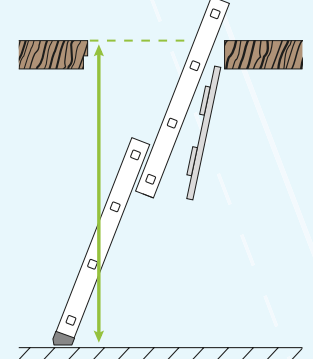

Floor to floor is the height of the floor of the room to the floor of the loft.

5
YEAR
GUARANTEE

The Loft Boys Guarantee

We offer a full 5 year guarantee on all our products and installation services and it's extremely rare for us to need to revisit a customer to fix a problem.

INDEPENDENT LOFT LADDERS

Stand-alone loft ladders with hatches not included



Deluxe 2 Section Loft Ladder

This top-rated deluxe 2 section sliding metal ladder is perfect for frequent, daily use, and features a powerful spring action which makes lowering or stowing effortless.

- Up to 150kg max load
- Full reach double handrails
- Lightweight aluminium
- Max. floor to floor height of 3.2m
- For minimum hatch size of 508mm x 686mm



Handrail



Non-slip treads



Rubber feet



Spring assisted

Code: D2Y

£487.00

Inc. VAT & Installation

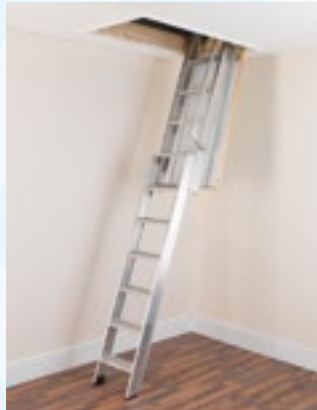

Superior 2 Section Loft Ladders

This robust, high specification 2 section sliding metal ladder is suitable for use in residential and industrial settings. It has a powerful spring action counterbalanced for ease of use.

- Up to 175kg max load
- Single handrail
- Lightweight aluminium
- Max. floor to floor height of 3.88m
- For minimum hatch size of 558mm x 762mm



Handrail



Non-slip treads



Rubber feet



Spring assisted

Codes: S25R/S28R/S31R/S33R/S36R/S38R

Available in various sizes

From £537.00

Inc. VAT & Installation



Telescopic Loft Ladder

This is one of our most advanced loft ladders we offer. The unique telescopic design allows for installation into the tightest of spaces. Spring assisted for easy use.

- Up to 150kg max load
- Extra deep treads
- Lightweight aluminium
- Max. floor to floor height of 2.88m
- For minimum hatch size of 520mm x 620mm



Non-slip treads



Rubber feet



Spring assisted

2.6m height

Code: T26Y

£397.00

Inc. VAT & Installation

2.9m height

Code: T29Y

£427.00

Inc. VAT & Installation

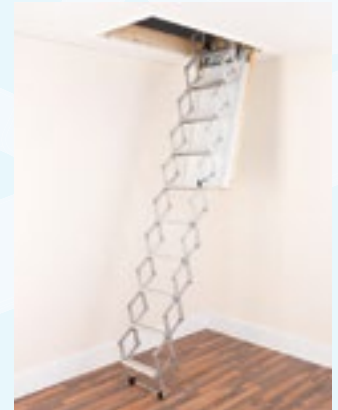

Concertina Loft Ladder

This ladder is ideal if clearance is limited around the loft hatch and it's adjustable gradient makes it highly versatile. Deep threads and spring assisted for ease of use.

- Up to 100kg max load
- Requires no space within loft
- Lightweight aluminium
- Max. floor to floor height of 3m
- For minimum hatch size of 500mm x 600mm



Non-slip treads



Spring assisted

2.73m height

Code: C27A

£367.00

Inc. VAT & Installation

3m height

Code: C30A

£397.00

Inc. VAT & Installation



INSTALLATION

Installation included on all ladders

All ladder prices displayed include installation by our highly experienced and skilled workers. See page 26 for more information and testimonials.



LWS Timber Folding Loft Ladder & Hatch

The LWS timber folding loft ladder comes pre-mounted onto an insulated, draft proof but unfinished faced trapdoor and hatch, making it ideal for people looking for fully integrated ladder but wish to finish in a colour of their choice. Supplied in either a 3 section or 4 section design, depending on size of hatch.

- Up to 160kg max load
- Lightweight timber
- Heat transmission of U=1,1
- Max. room height of 3.05m



Beige hatch



Non-slip treads



LWK Timber Folding Loft Ladder & Hatch

The LWS timber folding loft ladder comes pre-mounted onto an insulated, draft proof and pre-finished white faced trapdoor, making it ideal for people looking for fully integrated and low maintenance ladder. Supplied in either a 3 section or 4 section design, depending on size of hatch.

- Up to 160kg max load
- Single handrail
- Lightweight timber
- Heat transmission of U=1,1
- Max. room height of 3.05m



White hatch



Non-slip treads



Handrail



Rubber feet



LWL Lux Timber Folding Loft Ladder & Hatch

The LWL Lux timber folding loft ladder comes pre-mounted onto an insulated, draft proof and pre-finished trapdoor, making it ideal for people looking for a fully integrated and low maintenance ladder. Includes a double section handrail, ladder support and unloading mechanism for even safer use.

- Up to 160kg max load
- Single handrail
- Lightweight timber
- Heat transmission of U=1,1
- Max. room height of 3.05m



White hatch



Non-slip treads



Handrail



Rubber feet



Spring assisted

Integrated loft ladders explained

These ladders are supplied with insulated hatches & trapdoors and prices shown include full installation by our highly experienced team.

U-values explained

The U-value is the measure that incorporates the thermal conductance of a building together with the transfer of heat due to convection and radiation.

The lower the U-value, the lower the heat flow and the result is a greater energy saving due to a lower amount of energy required to maintain a consistent desired room temperature.

Code: FTFS D1 - D12
Available in 12 sizes

From **£437.00**
Inc. VAT & Installation

Accessories:

- Loft Balustrade
- Stile ends/feet (3 Section design only)
- Handrail (LXH 50/17 - LXH 75/17)
- Box Extension
- Upper Hatch (standard on 4 section designs)
- Additional Tread
- Unloading Mechanism (3 Section design only and over 1200mm in length)
- Insulation Kit

Code: FTFK D1 - D12
Available in 12 sizes

From **£437.00**
Inc. VAT & Installation

Accessories:

- Loft Balustrade
- Stile ends/feet (3 Section design only)
- Handrail (LXH 50/17 - LXH 75/17)
- Box Extension
- Upper Hatch (standard on 4 section designs)
- Additional Tread
- Unloading Mechanism (3 Section design only and over 1200mm in length)
- Insulation Kit

Code: FTFLX D1 - D7
Available in 7 sizes

From **£497.00**
Inc. VAT & Installation

Accessories:

- Loft Balustrade
- Stile ends/feet (3 Section design only)
- Box Extension
- Upper Hatch (standard on 4 section designs)
- Additional Tread
- Insulation Kit

INTEGRATED LOFT LADDERS

Loft ladders with hatches included



LTK Thermo Timber Folding Loft Ladder & Hatch

The LTK Thermo timber folding loft ladder comes pre-mounted onto a pre-finished, completely air tight, draught proof and fully insulated trapdoor, which achieves a U-value of 0.76 making this the perfect ladder for properties with significant temperature differences between the habitable space and loft. Supplied in 3 section only.

- Up to 160kg max load
- Lightweight timber
- Heat transmission of U=0,76
- Max. room height of 2.8m



White hatch



Non-slip treads



Handrail



Rubber feet



LWF Timber Folding Loft Ladder & Hatch

The LWF fire-resistant timber folding loft ladder acts as a blaze-block in the event of fire inside the building, thanks to its high fire-resistant properties, (EI2: 30 min). The LWF is perfect for installations subject to stipulations as specified in the building regulations. A unique special unloading mechanism eliminates the need for a lock.

- Up to 160kg max load
- Single handrail
- Lightweight timber
- Heat transmission of U=0,9
- Max. room height of 3.05m



White hatch



Non-slip treads



Handrail



Rubber feet



Fire-resistant hatch

Code: FTFKT D1 - D4
Available in 4 sizes

From **£497.00**
Inc. VAT & Installation

Accessories:

- Loft Balustrade
- Stile ends/feet (3 Section design only)
- Handrail (LXH 50/17 - LXH 75/17)
- Box Extension
- Upper Hatch
- Unloading Mechanism
- Insulation Kit

Code: FTFFR D1 - D8
Available in 8 sizes

From **£577.00**
Inc. VAT & Installation

Accessories:

- Loft Balustrade
- Stile ends/feet (3 Section design only)
- Handrail (LXH 50/17 - LXH 75/17)
- Box Extension
- Upper Hatch (standard on 4 section designs)
- Unloading Mechanism
- Insulation Kit

ACCESSORIES



Stile ends/feet (3 Section design only)

Plastic ladder feet and floor protectors.

Code: FSEP-1

£22.00
Inc. VAT



Box Extension

Pine Internal Lining box extension is to provide a tidy finish throughout the whole depth of loft hatch opening if having a 125mm raised loft floor.

Code: FBX

£TBC
Inc. VAT



Additional Tread

Additional tread is a useful feature for when the loft floor is to be raised 125mm or higher.

Code: FTT

From **£47.00**
Inc. VAT



Handrail

Feel more confident having the security of handrails when using your loft ladder? These handrails are available for use with our standard loft ladders and are even available as a second rail if your chosen ladder is already supplied with one.

Code: BHRY

£17.00
Inc. VAT



Upper hatch

The Upper hatch is designed as a safety measure for when using the loft space eradicating the risk of falling whilst minimising attic dust from accumulating on the ladder and trapdoor. Available for 3 section folding ladders & 125mm raised loft floors only.

Code: FTH3

From **£TBC**
Inc. VAT



Balustrades

Feel a little concerned about walking around your loft space with that huge hole in the floor? These balustrades or hatch safety guard rail helps keep you safe and prevents accidental falls when in your loft or attic space. The Metal Loft Balustrade can fit most loft ladder openings with an adjustable width of 500 to 750mm.

Wooden Code: WDHB

£137.00
Inc. VAT

Metal Code: MLHB

£147.00
Inc. VAT



PAN Metal Concertina Wall Access Ladder

Manufactured from pressed steel and fully galvanised, these heavy duty concertina style ladders can be used safely in the most demanding of situations and will easily cope with frequent use. They have an integral steel frame, which lines the hatch opening, for greater strength and durability.

- Up to 150kg max load
- Supplied with 2 handrails
- Zinc plated steel finish
- Includes steel hatch lining frame
- Max. room height of 3m



Non-slip treads



Handrail



Rubber feet



Spring assisted

Code: DVCP
Available in various sizes

From **£1097.00**

Inc. VAT & Installation

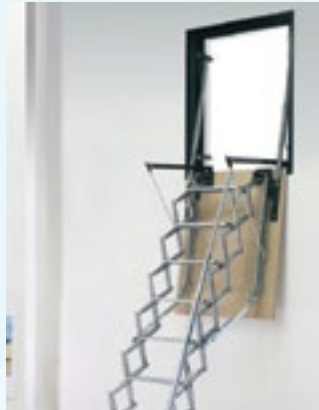

SAF Metal Concertina Wall Access Ladder

The SAF is a superb heavy duty, die cast aluminium, concertina ladder, complete with hatch door and frame, suitable for both commercial and domestic use. These heavy duty concertina style loft ladders can be used safely in the most demanding of situations and will easily cope with frequent use.

- Up to 150kg max load
- Single telescopic handrail
- Die cast aluminium
- Includes exit grab rails
- Max. room height of 3.5m



Non-slip treads



Handrail



Rubber feet



Spring assisted

Code: DVCF
Available in various sizes

From **£1097.00**

Inc. VAT & Installation

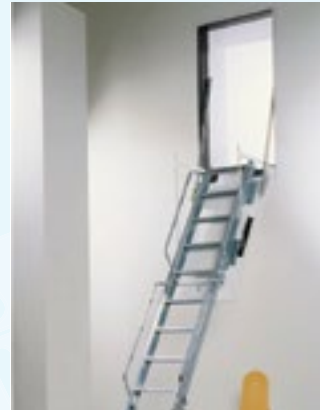

L3 Metal Folding Wall Access Ladder

The L3 features a fully spring balanced MDF trap door for easy and smooth operation, with a pressed steel ceiling hole lining for extra strength. They come with an integral architrave which covers the joint between the ladder frame and the hole in your ceiling so you don't have to pay extra for materials to make one.

- Up to 150kg max load
- Supplied with 2 handrails
- Includes exit grab rails
- Zinc plated steel finish
- Max. room height of 4m



Non-slip treads



Handrail



Rubber feet



Spring assisted

Code: DMFL
Available in various sizes

From **£917.00**

Inc. VAT & Installation

Wall access ladder sizes

PAN/SAF

1. 700mm x 500mm
2. 700mm x 700mm
3. 800mm x 500mm
4. 800mm x 700mm
5. 900mm x 500mm
6. 900mm x 700mm
7. 1000mm x 500mm
8. 1000mm x 700mm

PAN wall ladder heights:

- 2.50m (2.25 - 2.50) (Available in sizes 1/2/3)
Code: DVCP1 **£1097**
- 2.75m (2.51 - 2.75) (Available in Sizes 1/2/3)
Code: DVCP2 **£1117**
- 3.00m (2.76 - 3.00) (Available in sizes 1/2/3)
Code: DVCP3 **£1137**

SAF wall ladder heights:

- 2.50m (2.25 - 2.50) (Available in sizes 1/2)
Code: DVCF1 **£1097**
- 2.75m (2.51 - 2.75) (Available in Sizes 1/2)
Code: DVCF2 **£1167**
- 3.00m (2.76 - 3.00) (Available in sizes 1/2)
Code: DVCF3 **£1177**
- 3.25m (3.01 - 3.25) (Available in sizes 2/3/4)
Code: DVCF4 **£1197**
- 3.50m (3.26 - 3.50) (Available in sizes 2/3/4)
Code: DVCF5 **£1207**

L3

1. 1300mm x 700mm
2. 1400mm x 700mm
3. 1500mm x 700mm
4. 1600mm x 700mm
5. 1700mm x 700mm
6. 1800mm x 700mm
7. 1900mm x 700mm
8. 2000mm x 700mm
9. 2100mm x 700mm
10. 2200mm x 700mm

L3 wall ladder heights:

- 3.00m (2.75 - 3.00) (Available in sizes 1/3)
Code: DMFL1 **£917**
- 3.25m (3.01 - 3.25) (Available in sizes 2/3)
Code: DMFL2 **£927**
- 3.50m (3.26 - 3.50) (Available in size 3/4)
Code: DMFL3 **£997**
- 4.00m (3.56 - 4.00) (Available in sizes 5/6/7/8)
Code: DMFL4 **£1368**
- 4.50m (4.01 - 4.50) (Available in sizes 8/9/10)
Code: DMFL5 **£1547**

5
YEAR
GUARANTEE

The Loft Boys Guarantee

We offer a full 5 year guarantee on all our products and installation services and it's extremely rare for us to need to revisit a customer to fix a problem.

INSTALLATION

Installation included on all ladders

All ladder prices displayed include installation by our highly experienced and skilled workers. See page 26 for more information and testimonials.

Custom Made Hatches



Code: TCMH
£187.00
 Inc. VAT & Installation

Timber Hatch

Custom made timber loft hatch casing with fully insulated and draught proof 18mm hinged MDF trapdoor complete with lock and finished off with architrave to suit your home. This price covers removal of any old hatch if being installed into an existing opening.



Code: THDT
£97.00
 Inc. VAT & Installation

New Hinged Trapdoor

Need to replace the trapdoor to your loft for a solid hinged down one? We can custom make one to suit your loft hatch opening, which always come fully insulated and draught proof as standard!

Maintenance Free Hatches

Need to replace your old push up hatch with a hinge down type but like the idea of low maintenance? We have various types and sizes to suit most situations. We can even have these made to measure if our standard sizes won't fit the current hatch opening. Available in Steel and High impact polystyrene.



High Impact Polystyrene

This loft hatch meets the requirements of the BS 9250:2007 Code of Practice for design of the air tightness of ceilings in pitched roofs. With the twist latch operation and common size match this hatch is our most popular from our maintenance free range.



Lockable

The lockable drop down loft door is an innovative solution to the need for energy efficient loft space access for use in shared accommodation, offering a cost effective alternative to traditional means of access. The unobtrusive design coupled with sleek, contemporary styling makes the door an ideal match for modern decors. It is supplied with a key lock for additional security.

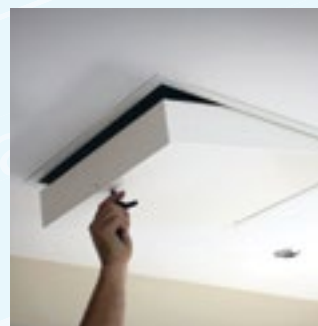

Steel Lockable

These premium steel loft hatches are finished in powder coated white and can be over painted to blend with the surrounding surface. The door Panel is a high quality robust access solution suitable for everyday use with all the discrete advantages you should expect. The spring loaded invisible keyhole provides a seamless finish, without the unsightly white caps that can spoil the finished design.



Upper Hatch

The upper hatch prevents attic dust from accumulating on the hatch and steps of the closed ladder. It improves the overall insulating parameters and air tightness of the ladder on which it is installed. The height of the upper hatch box is 20cm.

Size Options

50mm Insulation Code: MPH5 **£97**
 60mm Insulation (U-Value 0.35) Code: MPH6 **£107**
 150mm Insulation (U-Value 0.15) Code: MPH1 **£137**

Size Options

50mm Insulation Code: MLH5 **£127**
 60mm Insulation (U-Value 0.35) Code: MLH6 **£157**
 150mm Insulation (U-Value 0.15) Code: MLH1 **£187**

Size Options (mm)

550 x 550 Code: PASL1 **£137**
 600 x 600 Code: PASL2 **£137**

Accessories:

Optional long reach key/pole to operate the lock from the floor Code: PASLP **£35**

Size Options (mm)

500 x 800 £TBC	700 x 800 £TBC
550 x 1100 £TBC	700 x 940 £TBC
600 x 900 £TBC	700 x 1000 Special
600 x 940 Special	700 x 1100 £TBC
600 x 1000 Special	700 x 1200 £TBC
600 x 1100 £TBC	700 x 1300 £TBC
600 x 1200 £TBC	700 x 1400 £TBC
600 x 1300 £TBC	860 x 1300 Special
600 x 1400 £TBC	

Everything you need to retain heat and reduce your bills



Loft Floor Insulation

As we all know, heat rises, and in an uninsulated home, a quarter of heat is lost through the roof. Insulating your loft is an extremely effective way to retain heat within the home and reduce heating bills.

Did you know that you could save up to £240 per year on energy bills if your loft space is insulated correctly? Combine that with the fact that loft insulation is effective for at least 42 years and you can see how cost effective this job actually is.

If you have no insulation laid in the loft whatsoever or want a clear out of the old insulation that is present then you'll need to have 270mm of insulation laid to achieve the recommended level. This consists of 1 x 100mm of insulation laid between the current loft joists and 1 x 170mm of insulation laid perpendicular over the joists.

If you have good condition insulation laid between the joists already and just want a top up to increase the thermal efficiency then you may need an additional 100mm or 170mm laid.

Available Options

270mm mineral wool insulation	£16.00 per square metre
170mm mineral wool insulation	£11.00 per square metre
100mm mineral wool insulation	£9.00 per square metre

Roof Insulation

If you're using your loft space as a storage area then it may be worth considering insulating the inside of the roof. Doing this will help regulate the temperature in the loft as well as increase thermal efficiency.

A simple yet effective method is via the introduction of foil insulation to the inside face of the roof rafters. This insulation will retain heat within the loft in the colder months and reflect heat in the hotter months.

Available Options

Foil Insulation	£18.00 per square metre
Multifoil Insulation	£45.00 per square metre (inc retainer battens)

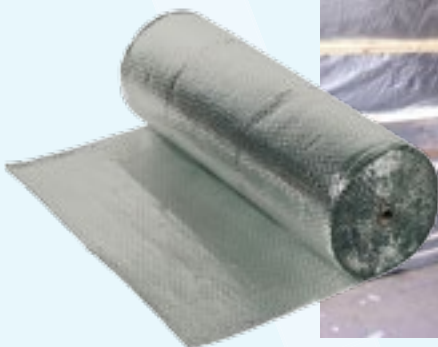

5
YEAR
GUARANTEE

The Loft Boys Guarantee

We offer a full 5 year guarantee on all our products and installation services and it's extremely rare for us to need to revisit a customer to fix a problem.



Natural light is by far the best way to illuminate any dark loft space, not only because it performs so well – bouncing around into every corner of loft space you allow it to enter – but also because it's 'free'. No switch needed here! Well, not during the day time at least!

We supply and install roof windows made by the market leader, VELUX, who produces extremely high-quality windows and our team have extensive experience fitting these windows.



VELUX Roof Windows

Pages 19-21



Roof Window Accessories

Page 21



Top Hung Roof Windows

VELUX top hung roof windows used in combination with fixed windows can transform a dusty roof loft into a bright usable loft space. Offering more headroom and a greater feeling of being outside, these windows will really help to make the most of the view. Operated with an elegant handle at the bottom, VELUX top hung roof windows give you a full, open view of your skyline and maximise the amount of natural daylight that can be allowed in. We recommend top-hung roof windows if you have to, or wish to, place your window in a high position, for instance in connection with a high knee wall.

Top Hung Size Guide (mm)

30° Opening	 White finish	
550 x 980	Code: SC/GHU/CK04	£767.00
780 x 980	Code: SC/GHU/MK04	£807.00
660 x 118	Code: SC/GHU/FK06	£827.00
780 x 118	Code: SC/GHU/MK06*	£857.00
780 x 140	Code: SC/GHU/MK08*	£927.00
1140 x 1180	Code: SC/GHU/SK06*	£1027.00

30° Opening	 Pine finish	
550 x 980	Code: SC/GHL/CK04	£717.00
780 x 980	Code: SC/GHL/MK04	£747.00
660 x 118	Code: SC/GHL/FK06	£767.00
780 x 118	Code: SC/GHL/MK06*	£787.00
780 x 140	Code: SC/GHL/MK08*	£857.00
1340 x 980	Code: SC/GHL/UK04*	£917.00
1140 x 1180	Code: SC/GHL/SK06*	£947.00

45° Opening	 White finish	
550 x 980	Code: SC/GHU/CK04	£827.00
780 x 980	Code: SC/GHU/MK04*	£857.00
660 x 118	Code: SC/GHU/FK06*	£887.00
780 x 118	Code: SC/GHU/MK06*	£927.00
780 x 140	Code: SC/GHU/MK08*	£997.00

45° Opening	 Pine finish	
780 x 118	Code: SC/GPL/MK06*	£867.00
780 x 140	Code: SC/GPL/MK08*	£927.00
1140 x 1180	Code: SC/GPL/SK06*	£1037.00

*Suitable for fire escapes



Centre Pivot Roof Windows

A centre-pivot roof window is easy to operate - even with furniture beneath. The innovative top control bar allows you to install the window lower than an equivalent top-hung operated roof window to get an excellent view while standing and when seated.

We recommend centre-pivot windows if you have to, or wish to, place your window in a low position, for instance: in rooms with a low ceiling or where you'd like a better view of the surroundings below.

Centre Pivot Size Guide (mm)

 White finish		
550 x 780	Code: SC/GGU/CK02	£647.00
550 x 980	Code: SC/GGU/CK04	£667.00
550 x 118	Code: SC/GGU/CK06	£687.00
780 x 980	Code: SC/GGU/MK04	£707.00
660 x 118	Code: SC/GGU/FK06	£737.00

 Pine finish		
550 x 780	Code: SC/GGL/CK02	£587.00
550 x 980	Code: SC/GGL/CK04	£607.00
550 x 118	Code: SC/GGL/CK06	£617.00
780 x 980	Code: SC/GGL/MK04	£637.00
660 x 118	Code: SC/GGL/FK06	£667.00

Window Finishes



White Polyurethane

- Perfect for contemporary interiors and white ceilings.
- Ideal for humid rooms such as kitchens and bathrooms.
- Requires less maintenance than lacquered natural pine.
- High quality moulded polyurethane with white lacquer finish and timber core.



Lacquered Natural Pine

- Ideal for a traditional interior.
- High quality natural pine.
- Protective triple coat clear lacquer helps to preserve the timber of the window.

Opening Angles



30° Openings

- SC-GHL and SC-GHU windows open to 3 positions - 5/15/30 degrees.
- These windows are designed for lower roof pitches.

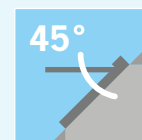

45° Openings

- SC-GPL and SC-GPU windows open to any position up to 45 degrees.
- These windows are intended for higher roof pitches.
- Due to the wider openings a large selection of these windows are suitable for fire escape purposes.



The Loft Boys Guarantee

We offer a full 10 year guarantee on all window parts and installation.

By Velux

INTEGRA® Benefits



Fresh air and a better indoor comfort

Sleeping, showering and cooking all increase the overall humidity levels in our homes. Poor indoor air quality seriously affects our general well being, but a few daily routines can have a great effect on your indoor comfort. Let VELUX INTEGRA® roof windows give you a helping hand. Simply use the pre-defined ventilation programs and enjoy automatic airing.



Worry-free home security

Imagine if you could close all your roof windows with a single touch. Now you can, with the intelligent VELUX INTEGRA® control pad. Simply press the "Leaving home" icon and all of your VELUX INTEGRA® roof windows will close at once wherever they are located in your house.

No chance of rain

What if it starts to rain and you're not around, or too busy, to close your windows? All of our VELUX INTEGRA® roof windows come with a rain sensor that closes your windows automatically if it starts to rain – so you never have to worry about the rain damaging your home.



Centre Pivot INTEGRA® Roof Window (electric or solar powered)

The VELUX INTEGRA® Electric Roof Window has a fully integrated motor which runs almost without a sound. The window is operated by the new VELUX INTEGRA control pad with touch screen and swipe function which uses icons for easy and intuitive control. The ventilation flap allows you to ventilate the room even when the window is closed. Due to the new Thermo Technology the INTEGRA® windows obtain a sufficiently low U-Value and an excellent energy efficiency. Click-on covers make the installation of the window easy, fast and safe. Electric blinds are available for this window. This window is suitable for roof pitches between 15°-90° and has a ten year guarantee.

The solar roof windows has all the same features as the electric roof window, but is powered by the sun. Pv solar cells on the window frame requires direct sunlight. There is no need to plug anything into a power supply with this window making it even quicker to install.

Mains Powered Size Guide (mm)

White finish		Pine finish			
550 x 780	Code: SC/GGU/CK02/EL	£927.00	550 x 780	Code: SC/GGL/CK02/EL	£887.00
550 x 980	Code: SC/GGU/CK04/EL	£957.00	550 x 980	Code: SC/GGL/CK04/EL	£917.00
550 x 118	Code: SC/GGU/CK06/EL	£977.00	780 x 980	Code: SC/GGL/MK04/EL	£937.00
780 x 980	Code: SC/GGU/MK04/EL	£997.00	660 x 118	Code: SC/GGL/FK06/EL	£967.00
660 x 118	Code: SC/GGU/FK06/EL	£1017.00			

Solar Powered Size Guide (mm)

White finish		Pine finish			
550 x 780	Code: SC/GGU/CK02/SL	£957.00	550 x 780	Code: SC/GGL/CK02/SL	£917.00
550 x 980	Code: SC/GGU/CK04/SL	£987.00	550 x 980	Code: SC/GGL/CK04/SL	£947.00
550 x 118	Code: SC/GGU/CK06/SL	£1017.00	550 x 118	Code: SC/GGL/CK06/SL	£967.00
780 x 980	Code: SC/GGU/MK04/SL	£1047.00	780 x 980	Code: SC/GGL/MK04/SL	£987.00
660 x 118	Code: SC/GGU/FK06/SL	£1077.00	660 x 118	Code: SC/GGL/FK06/SL	£1007.00

Please note: These ladders require a power socket within 1 metre of the ladder. Please see our [Lighting & Power](#) section for prices (pg 17).

10
YEAR
GUARANTEE

The Loft Boys Guarantee

We offer a full 10 year guarantee on all window parts and installation.

Flashing Kits

Flashing Kits are required on all VELUX windows to insure the windows are water tight. Available in all sizes to suite window type.



EDZ

Flashings for installing one roof window in a flat or profiled roofing material. Minimum profile of 15mm and a maximum profile of 45mm. Suitable for 20°-90° roof pitches.

Code: SC/EDZ

Inc in fitted price of roof window

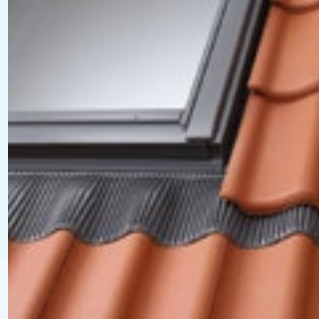

EDW

Flashings for installing roof windows in flat or profiled material up to 120mm in profile. Also for interlocking slate, thatch and profile sheeting. Suitable for 15°-90° roof pitches.

Code: SC/EDW

Inc in fitted price of roof window



EDL

Flashings for installing roof windows into non-interlocking slate up to 8mm thick. Suitable for 15°-90° roof pitches.

Code: SC/EDL

Inc in fitted price of roof window



EDP

Flashings for installing Roof windows in plain tiles (max length 340mm). Maximum thickness of 15mm. Suitable for 25°-90° roof pitches.

Code: SC/EDP

Inc in fitted price of roof window

Window Blinds



Roller Blinds

The VELUX roller blind provides basic privacy whilst still allowing natural light in. A roller blind is an affective and practical solution that offers protection and good looks. Roller blinds are therefore well suited for all requirements wherever the window may be situated.

Size Options (mm)

550 x 780	Code: SC/GGL/CK02/RFL
550 x 980	Code: SC/GGU/CK04/RFL
550 x 118	Code: SC/GGU/CK06/RFL
780 x 980	Code: SC/GGU/MK04/RFL
660 x 118	Code: SC/GGU/FK06/RFL



Blackout Blinds

The VELUX blackout blind gives you darkness 24/7. It has a reflective aluminium coating on the rear side that reflects heat from the sun in summer whilst retaining heat in winter months. Blackout blinds are ideal for installing in bedrooms, children's rooms, lofts and hobby rooms. They are of a modern design and fully integrated into the roof window, installation of these blinds are off a pick&click system enabling the user to fit the blind in no time at all.

Size Options (mm)

550 x 780	Code: SC/GGL/CK02/DKL
550 x 980	Code: SC/GGU/CK04/DKL
550 x 118	Code: SC/GGU/CK06/DKL
780 x 980	Code: SC/GGU/MK04/DKL
660 x 118	Code: SC/GGU/FK06/DKL

We supply a wide range of Velux window blinds in various colours and finishes, please call us for assistance and pricing.

VENTILATION SYSTEMS

Combat condensation problems with good ventilation

Why do I need Ventilation in the roof space?

Normal daily activities whilst living in a property (showers, cooking, drying washing) product warm air that contains water vapor. If this vapor can't escape the habitable part of your home it'll move around until it locates a cold surface where it cools and condensates.

The current recommended level of insulation, although being a great way to keep your home warm, highly reduces the amount of heat that can enter the roof which in turn creates the perfect place for airborne water vapor to condensate. The usual and most practical way to eliminate condensation is to remove the vapor from the loft space via some means of ventilation.

These are the common methods we use to deal with this issue (the quantity needed will be subject to size of roof space to be vented):



Felt Lap Vent

This vent is a refurbishment product designed to increase the amount of ventilation into existing roof spaces. Usually fitted retrospectively to properties with additional loft insulation recently installed.

£6.17 Each

Inc. VAT & Installation



Soffit Disc Ventilators

These vents can be slotted into the soffit board prior to installation for new build situations or just as easily retro-fitted into existing soffits.

£12.00 Each

Inc. VAT & Installation*



Roof Ventilation Tiles

The tile vent suits most concrete interlocking roof tiles and can be used to ventilate roof voids or as a terminal for soil and ventilation pipes and mechanical extraction systems.

From £57.00 Each

Inc. VAT & Installation*

*Subject to survey due to possibilities of asbestos being present.

5
YEAR
GUARANTEE

The Loft Boys Guarantee

We offer a full 5 year guarantee on all our products and installation services and it's extremely rare for us to need to revisit a customer to fix a problem.

Electrical lighting and power options for your loft space



All electrical work is carried out by NIC EIC approved contractors and certified on completion. Although we aim to complete this work as planned current wiring conditions sometimes dictate otherwise and we will always inform you of changes required should this be the case. We never under any circumstances complete work that can not be certified.

Please see below a price list of our most common electrical tasks. Should you have any further requirements that are not listed please get in touch as we may still be able to help.

Lighting

All loft light switches are located in a convenient position within the loft space.



Battery Powered LED Loft Light

This Loft Light is an ultra bright, battery powered LED light that illuminates a loft instantly and easily, requiring no electrical wiring.

£29.99

Inc. VAT

Available Options

Single bulb holder & switch	£147.00
Additional bulb holders on same circuit	£67.00
4' Fluorescent strip light & Switch	£177.00
Additional on same circuit	£77.00
6' Fluorescent strip light & Switch	£197.00
Additional on same circuit	£97.00
Battery Powered LED Loft Light	£29.99
Sun Tunnel Light Kit	£267.00

(Additional works may be required - Please confirm)



Power Sockets

If you are having an electric loft ladder or roof window you will need to a single socket for each.



Available Options

Single Socket	£237.00
Additional single socket on same circuit	£117.00
Double Socket	£247.00
Additional double socket on same circuit	£137.00

The Loft Boys are specialist loft boarders

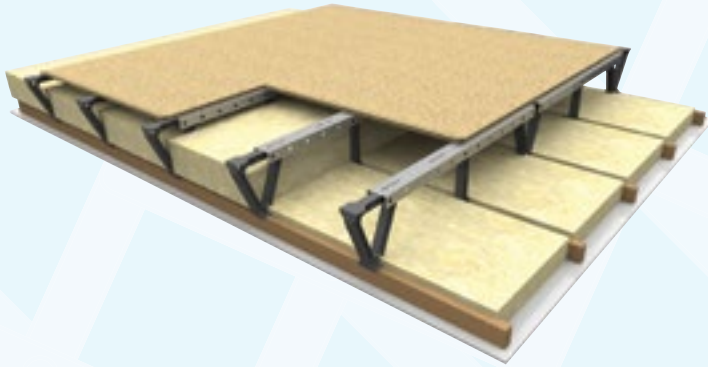

The Loft Boys specialise in the boarding of loft floors for the purpose of storage so if you are fed up with stumbling across timber joists and want the ideal home storage room then look no further.

On most occasions a new loft floor will need to be raised to sit above the current joist height due to electrical cables and pipes that travel over the existing floor level. It's also extremely important to maintain airflow beneath the floor to remove any possible condensation build up.

The height a floor may need to be raised is also dictated by the depth of insulation that is either present or required. The raising of a loft floor can be achieved by installing cross bracing or the LoftZone™ StoreFloor system.

Below is a list of our most popular floor designs which are dictated by roof design and insulation levels.

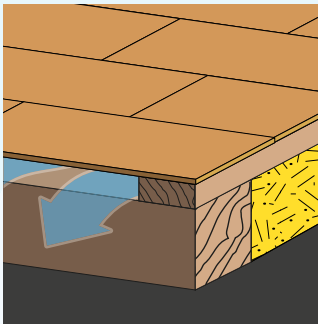

25mm Cross Bracing

25mm cross bracing and 18mm chipboard flooring is perfect if the current insulation depth is now higher than the top of the joists, and if there are no water pipes present in the area that the floor is to be laid.

£32.00 per square metre
Inc. VAT & Installation

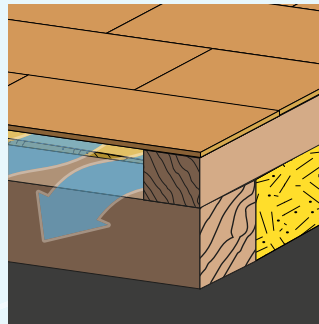

50mm Cross Bracing

50mm cross bracing and 18mm chipboard flooring is perfect if the current insulation depth is now higher than the top of the joists but the floor will need to be raised to sail over any pipes that are present within the area.

£35.00 per square metre
Inc. VAT & Installation

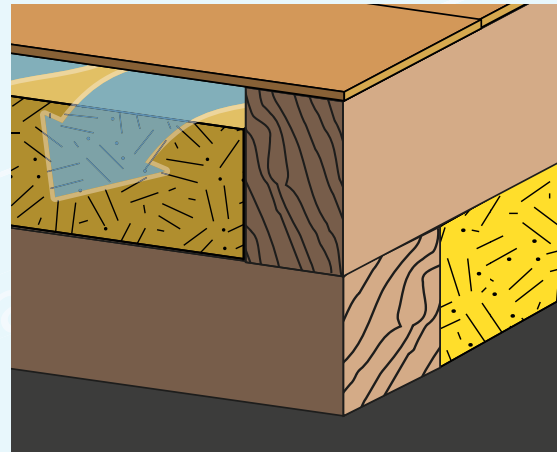

125mm Cross Bracing

125mm cross bracing and 18mm chipboard flooring is the maximum height that a loft floor can be raised using the cross bracing method. This is perfect if you are looking to lay additional insulation beneath the new floor but don't have the head room to accommodate the loft zone product. Also a very useful height to raise if there are existing ceiling braces in place and you'd like a completely flat floor.

£45.00 per square metre
Inc. VAT & Installation

The Loft Boys are also approved LoftZone™ installers



The cheapest and simplest solution to the very common problem of storing items in a fully-insulated loft is to install a raised floor above the insulation. Introducing the fantastic StoreFloor system by LoftZone™.

The LoftZone™ StoreFloor is a lightweight, low cost, easy-to-install and very strong platform for storing items and walking on, while protecting the 270mm loft insulation and allowing it to save energy and cut fuel bills as intended.

£65.00 per square metre
Inc. VAT & Installation

Loft Zone is ideal for new build properties with the current recommended depth of insulation (270mm). This system allows the loft floor to be raised above this level of insulation without overloading the joists.

- Allows insulation to stay intact, saving you £££'s
- Lightweight - does not overload joists like alternative systems
- Safe to walk on and store items on
- All materials are made in the UK
- Can be added to in the future as your storage needs increase



INSTALLATION SERVICES

Find out more about The Loft Boys high-quality installation services



We have extensive experience installing everything you can think of to do with lofts, from floor boarding and insulation, to roof windows and loft ladders. We also install all the small stuff like light switches and extra power sockets and only ever use fully qualified NIC EIC registered electricians.

We take great pride in our quality and professionalism and every loft job we carry out is treated as our only job and all staff fully understand that the success of this job will lead us onto to the next. Taking this attitude means that you, your home and possessions will be looked after and treated with the utmost respect. Being specialists means that we are able to work to an extremely high standard within a very short period of time, minimising the inconvenience of having workers in your home.

The knowledge and processes we have gained over the years means that you can rest at night knowing that you are in safe hands. Our high quality of service and installations enabled us to become the only LoftZone 'Certified Installer' in London and the home counties. LoftZone are the UK's largest manufacturer of safe loft storage systems that a comply with building regulations.

If you would like to know more about our services please call us today on: 0800 6128 933 or email lofts@theloftboys.co.uk

“Excellent service from start to finish. Professional staff. Very impressed with the product, price, installation and customer service.”

Daniel Bond - Cambridge

“Excellent service from initial approach to the final completion of the work. Phil and Mike worked hard to complete in a timely fashion, but were always happy to explain and answer any questions. Thank you Loft Boys - a job very well done and I feel it is good value for money.”

Jackie Melsom - London

“Fabulous - Has made a massive difference already. Would definitely recommend The Loft Boys.”

E Cavey - Colchester

Installer partners



LOFTZONE
STOREFLOOR
AUTHORISED INSTALLER

Powered by



The Leading Loft Boarding & Ladder Experts in the UK





THE LOFT BOYS



The Loft Boys Ltd.
Unit 10 Impressa Park
Pindar Road, Hoddesdon
Herts, EN11 0DL

Tel: 0800 6128 933
Tel: 01992 679077

Email: lofts@theloftboys.co.uk
Web: www.theloftboys.co.uk